

No. 766 Saran Cut-Off Tool

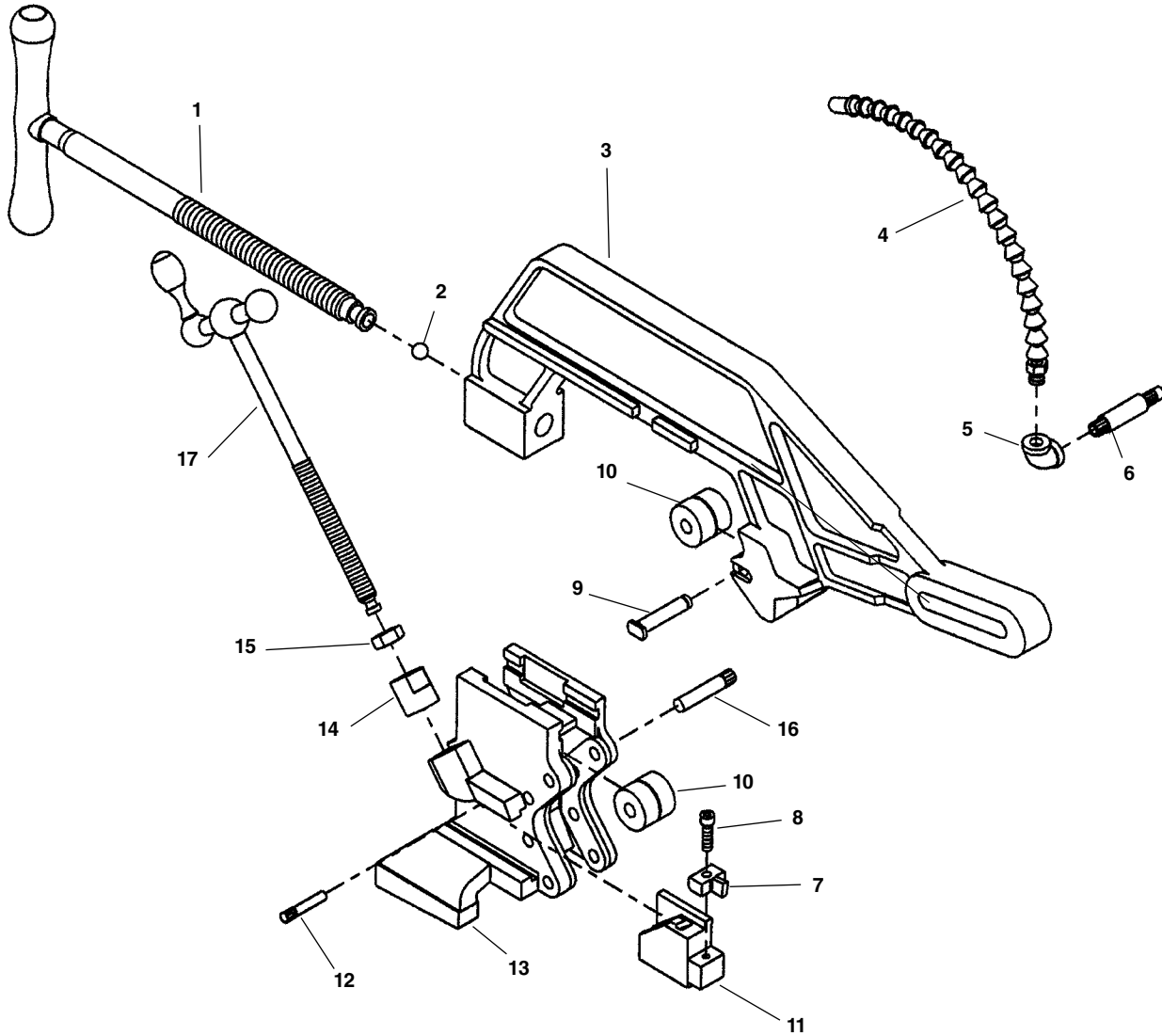

**NOTE: Order parts by Catalog Number only.
DO NOT order by Reference Number.**

Ref. No.	Catalog No.	Description
—	55452	766 Saran Cut-Off Tool
1	26752	Feed Screw Handle
2	41730	Steel Ball
3	26742	Cutter Frame
4	39845	Coolant Nozzle
5	39855	90° Elbow
6	57522	Carriage Bypass Pin
7	58712	Tool Bit
8	27357	Screw 1/4" - 20 x 7/8"
9	56932	Pin
10	34785	Rolls (5)
11	58717	Tool Holder Slide
12	26757	Groove Pin
13	58722	Roll Housing
14	58697	Adjustment Nut
15	44745	Jam Nut
16	26762	Groove Pin (4)
17	40027	Feed Screw Assembly
—	46190	1/4" Hex Key
—	49737	Lockout Plate F/Die Head

“ML” Oil Pump

**NOTE: Order parts by Catalog Number only.
DO NOT order by Reference Number.**

Ref. No.	Catalog No.	Description
—†	27307	“ML” Oil Pump
1	33442	Pump Valve Body
2	33432	Compression Fitting (2)
3*	33457	Gasket (Set of 2)
4*	33452	Valve Retainer Assy.
5	33482	Gerotor Housing w/Bearing
6*	33477	O-Ring
7†	33462	Sleeve Bearing
8	33467	Gerotor Set
9	33447	Pump Cap w/Seal
10*	33472	Oil Seal
11	44510	Soc. Hd. Cap Screw 1/4" - 20 x 2"
12	45150	Lock Washer 1/4"
*	33422	“ML” Service Kit

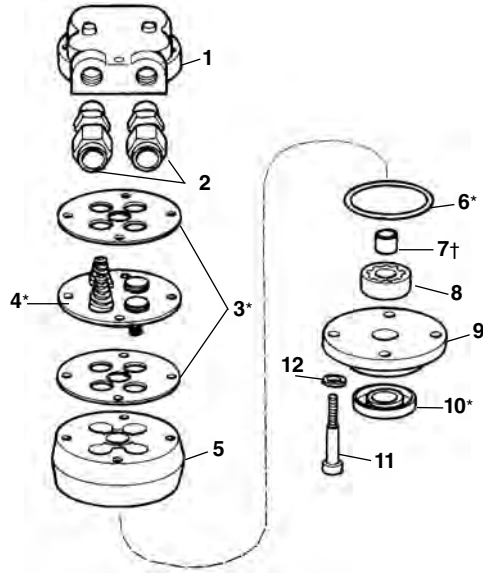

Note: Ref. 7 Sleeve Bearing used on older Gerotor Housings, not required on new pumps.
* Indicates Part is Included in Service Kit.
† See Service Note

No. 764 Pipe Cutter

Ref. No.	Catalog No.	Description
—	26212	764 Pipe Cutter
1	26752	Screw Handle
2	41730	Ball Bearing
3	26742	Cutter Frame
4	26747	Roll Housing
5	26757	Groove Pin
6	26762	Groove Pin (2)
7	33125	Cutter Wheel
8	34785	Roll (2)
9	26252	Roll F/Coated Pipe (2 per set)
10	34790	Wheel Pin
11	27072	Groove Pin

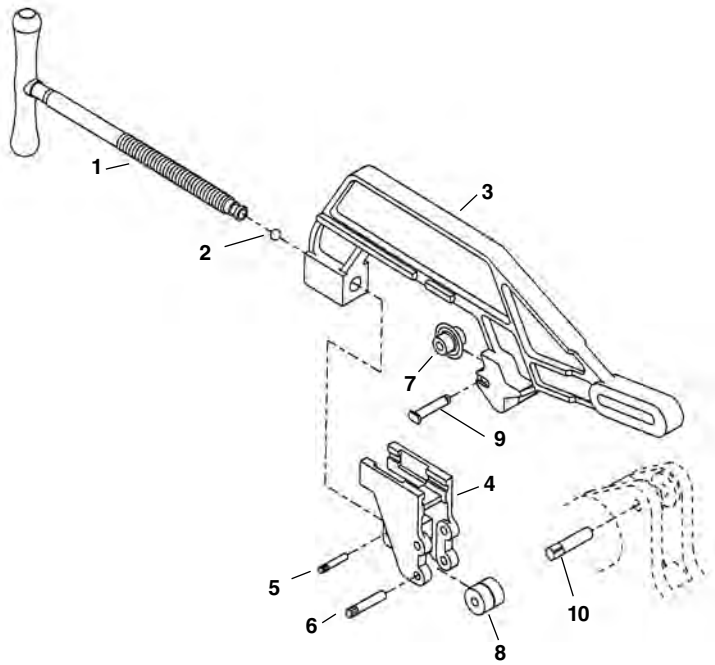

No. 744 Reamer Assembly

Ref. No.	Catalog No.	Description
—	26217	744 Reamer Assembly
1	26602	Reamer Arm
2	34577	Reamer Blade 1/4" - 4"
3	27037	Shoulder Bolt
4	27072	Groove Pin
5	26607	Pivot Block
6	26727	Groove Pin (2)

